

Enphase Energy System planning guide for grid-tied IQ Battery 5P with FlexPhase

Applicable regions: Austria, Germany, Switzerland

© 2025 Enphase Energy. All rights reserved. Enphase, the e and CC logos, and certain other marks listed at <https://enphase.com/trademark-usage-guidelines> are trademarks of Enphase Energy, Inc. in the U.S. and other countries. Data subject to change.

1. About this document

This guide contains information for site surveyors and design engineers to analyze a site and plan the design, installation, and support of home energy systems using the Enphase Energy System (EES). This guide is not for installation and operation. This document supplements the information in the data sheets, quick install guides (QIGs), and product manuals. The diagrams and information are demonstrative of system configurations and installations. However, they may not include all additional local standards and regulations applicable to a site.

2. Enphase Energy System overview

The following table lists the three use cases supported by EES.

Table 1: Use cases

Energy sources at the site	Description
Solar Only	<p>This configuration is ideal for homeowners who want to go solar and optimize their electricity bill savings.</p> <p>By producing and consuming the electricity generated from their solar plant, homeowners reduce their dependence on the grid and go green.</p>
Solar plus battery	<p>Pairing IQ Microinverters with IQ Batteries, this grid-tied configuration combines solar and storage to help maximize financial benefits.</p> <p>A Solar plus battery system makes a home more energy-independent and can offer significant long-term savings by minimizing the homeowner’s electricity bills. In this configuration, the microinverters power the house with solar energy when the sun shines. Excess solar energy is used to charge the IQ Batteries. Once the battery is fully charged, the extra solar energy is exported back to the grid in exchange for electricity bill credits (in countries that allow it). Once the sun sets, the battery powers the home.</p>
Battery upgrade (installed on existing PV site)	<p>If a home has an existing solar system—either Enphase solar or a string inverter system—adding IQ Batteries can help maximize financial benefits by storing excess solar power. Use this stored energy to power the home once the sun sets.</p>

3. Product overview

- IQ Gateway:** This communications gateway can communicate with all Enphase Energy System components such as the IQ Series Microinverters and the IQ Batteries. IQ Gateway is the brain that controls the entire system, collects performance information and transfers it to the Enphase Cloud.

- **IQ Series Microinverters and accessories:** IQ Series Microinverters pack more power into less space than other rooftop solar systems and make rooftop solar more productive, reliable, smart, and safe.
- **IQ Battery 5P with FlexPhase:** This is an all-in-one AC-coupled battery system, that is powerful, reliable, simple, and safe. The battery can be flexibly used in both single-phase and three-phase applications. It has a total usable energy capacity of 5.0 kWh and includes six embedded IQ8T-BAT Microinverters providing up to 3.84 kVA continuous power in single-phase configuration (country-specific ratings may vary) and 1.28 kVA continuous power per phase in three-phase configuration.
- **IQ Combiner 2 EU 3P:** The IQ Combiner 2 EU 3P consolidates interconnection equipment into a single enclosure and streamlines solar and storage installations, leading to significant installation time savings. It includes the IQ Gateway Metered, two IQ Relays, a Communications Kit 2, two 4-pole circuit breakers, an IQ Gateway circuit breaker, and a residual current device (RCD) pre-installed on a three DIN rail assembly.
- **Communications Kit 2 INT:** It enables the IQ Gateway Metered to communicate with IQ Battery 5P using wired control (CTRL) communication. The Communications Kit 2 is connected via USB to the IQ Gateway.
- **Current transformers:** Required to monitor PV production and home energy consumption. They are essential for the Enphase Energy System to operate correctly.
- **Control cable:** The control cable enables communication between the IQ Gateway and the IQ Battery 5P with FlexPhase.

4. Product generation and interoperability

Table 2: Supported and unsupported configurations with the IQ Battery 5P

Product	IQ Battery 5P with FlexPhase-grid-tied
IQ7 Series	Yes
IQ8 Series	Yes
IQ7 Series and IQ8 Series	No ¹
M Series	No ²
IQ7/IQ8 Series and M Series	No ²
String inverter	Yes
String inverter and IQ7/IQ8 Series	Yes ³
AC battery	No ⁴
IQ Battery 3T/10T	No ⁴

¹ IQ7 and IQ8 PV can't be supported on the same IQ Gateway. The IQ Battery 5P can be installed on either the IQ Gateway with the IQ7 or the IQ Gateway with the IQ8. However, two different Gateways are needed, and a PLC filter is required to segregate the PLC of the two IQ Gateways.

² M Series Microinverters and the IQ Battery 5P with FlexPhase need to be installed on separate gateways.

IQ7/IQ8 Microinverters can be installed on the same gateway as IQ Battery 5P with FlexPhase.

³ This is supported for grid-tied sites without a power export limit (PEL).

⁴ AC battery and IQ Battery 3T/10T are not compatible with IQ Battery 5P with FlexPhase because the mode of communication for the prior generations (PLC/wireless Zigbee) and IQ Battery 5P with FlexPhase (wired control communication) is not compatible with each other.

5. Design an Enphase Energy System

5.1 System profiles

The Enphase Energy System supports the following system profiles of operation:

- **Self-Consumption:** The PV system and battery are optimized to enable maximum self-consumption of energy produced by the PV system. The battery's capacity caters to home loads to minimize energy import from the grid.
 - **Charge-from-grid:** This is an advanced battery setting in the self-consumption profile where the battery can charge from the grid during a specific schedule set by the user.
 - **Discharge-to-grid:** This is an advanced battery setting in the self-consumption profile where the battery can discharge to the grid during a specific schedule set by the user.
- **AI Optimization:** Maximizes savings by using electricity rates, consumption patterns, and solar forecast. Works with "Time of Use" or dynamic tariff rates in regions where applicable. Consult local websites for availability in your country.

5.2 System considerations

Read each product's quick install guides (QIG) for detailed information about installing the Enphase Energy System.

As a reference for electrical symbols, refer to the following legend to comprehend the system diagrams in a better way. The following sample Enphase Energy System diagrams help to design your PV and storage systems.

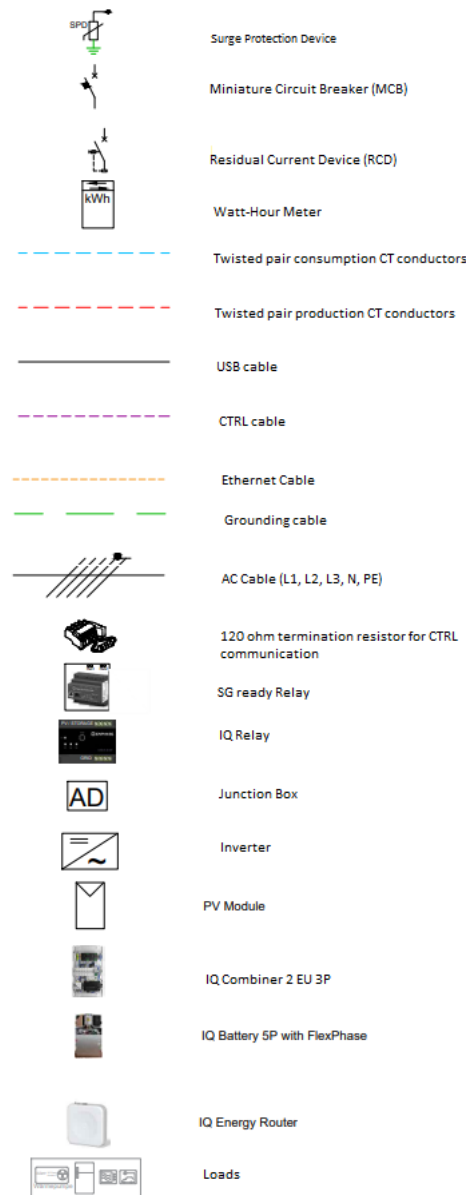

Figure 1: System diagram: Legends

IQ Gateway:

- The IQ Gateway Metered standalone can monitor up to 300 IQ Microinverters.
- The IQ Gateway Metered standalone ships with two current transformers (CTs) - one for production metering and the other for consumption metering. Ordering and using four additional CT-100-SPLIT-ROW or CT-100-SPLIT (two each for monitoring the additional production and consumption channels) is essential for three-phase systems. CT-100-SPLIT-ROW is optimal for smaller consumer units with cable sizes up to 16 mm²; CT-100-SPLIT can be used for larger cable sizes up to 50 mm²; CT-400-SPLIT-INT can be used to accommodate cable sizes up to 150 mm².

IQ Microinverters:

- Determine the length and cross-section of the AC conductor between the junction with the IQ Cable and the electrical panel per the local electrical regulations. It is recommended that the voltage drop across these conductors does not exceed 1% and that the overall voltage drop in the PV circuit from the point of connection to the most remote microinverter does not exceed 2%. Depending on the size of the PV system and the length of the cable, the cross-section in the supply line must be increased.
- Install any equipotential bonding between PV module frames, array mounting structures, and metal microinverter mounting brackets per local electrical regulations.
- In three-phase systems, microinverters should be balanced across the three phases to avoid phase imbalance.
- Generally, a 20 A B-curve circuit breaker is installed to protect the 2.5 mm² IQ Cable per PV circuit. Ensure your microinverters in the branch circuit do not exceed 16 A. However, it is essential to understand and follow local regulations where this may not be the case.
- Surge protection devices (SPD) and residual current devices (RCD/FI) must be installed in accordance with the electrical standards applicable in the country of installation. Enphase microinverters have an integrated SPD device of type III.
- The microinverters contain an RF transformer that ensures the function of galvanic isolation between the DC PV module and the AC network. In accordance with this, Type A or Type B RCDs may be required depending on the electrical standards applicable to the installation.
- Enphase offers a multi-phase 4-core (L1, L2, L3, N) or single-phase 2-core (L + N) cable with 2.5 mm² (Q-RAW, H07BQ-F, UV-resistant and maximum operating temperature of 90°C) as a supply line or as an extension of the IQ Cable. If the cable length and the associated voltage drop are too great, a larger cross-section with a 3 or 5-core NYM, NYY, or comparable cable must be used depending on the type of installation and location.
- PV systems >30 kVA must be equipped with central grid coupling protection.

IQ Battery 5P with FlexPhase:

NOTE: Sites with a combination of IQ Battery 5P with FlexPhase configured as single-phase and three-phase are not supported. All the batteries on site can either be configured as three-phase or one-phase.

- The IQ Battery 5P with FlexPhase is delivered to the site with the jumper block pre-installed on the AC terminals making it a one-phase battery by default. To utilize the battery in three-phase configurations, simply pull out/remove the jumper block from the AC terminals.
- In three-phase systems, it is recommended to install the IQ Battery 5P with FlexPhase across three phases for balanced operation. Installing the battery as a single-phase device can result in phase imbalance and system performance issues.
- Installed with standalone IQ Gateway Metered: Procure the Communications Kit 2 for enabling communication between the IQ Gateway and the IQ Battery.
- Up to five IQ Battery 5P units in a three-phase configuration can be connected on a single circuit.
- The battery terminals are compatible with a conductor size between 2.5–10 mm² (without ferrule) in three-phase configurations. Use a 10 A B curve circuit breaker for one IQ Battery 5P or a maximum 40 A B curve circuit breaker for five IQ Battery 5P units. Follow all local standards and regulations while selecting the AC circuit breaker.
- When installing the IQ Battery 5P with FlexPhase in a three-phase configuration and IQ PV with the IQ Combiner 2 EU 3P or a standalone IQ Gateway Metered, the maximum number of batteries supported is detailed below:

Table 3: Maximum IQ Battery count supported

IQ Battery 5P with FlexPhase	Maximum IQ Battery count supported	
	IQ Combiner 2 EU 3P	IQ Gateway Metered standalone
Configured as three-phase	A circuit of 3 batteries per three-phase IQ Relay	A circuit of 3 batteries per IQ Relay Total battery count supported = 15

Others:

Installers must procure a suitable length of control cable for the installation. Procure the required length of the control cable from your Enphase distributor. The Enphase order code for the cable is CTRL-BL-EU-01.

 **NOTE:** Enphase requires the use of an Enphase Control Cable for optimal performance of the Enphase Energy System. Enphase cannot guarantee performance when a third-party cable is used.

The following sample Enphase Energy System diagrams help you design your PV and storage systems.

5.2.1 Solar PV only: Three-phase IQ7/IQ8 Series Microinverters with IQ Combiner 2 EU 3P

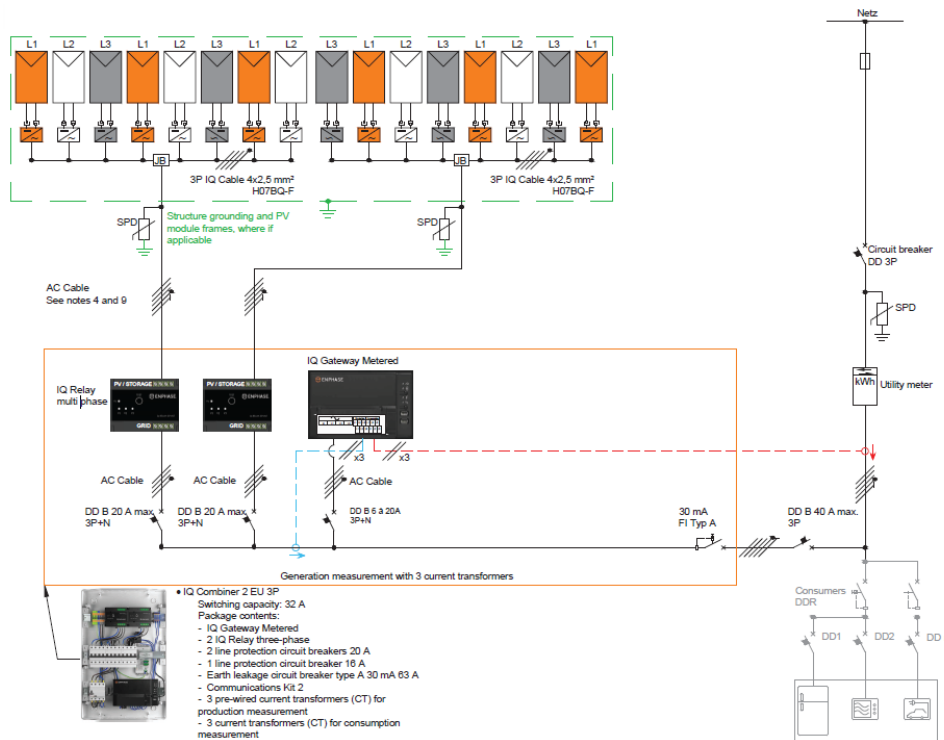

Figure 2: Three-phase IQ7/IQ8 Series Microinverters with IQ Combiner 2 EU 3P diagram

5.2.2 Solar PV and battery: Three-phase IQ7/IQ8 Series Microinverters and IQ Battery 5P with FlexPhase configured in three-phase with IQ Combiner 2 EU 3P

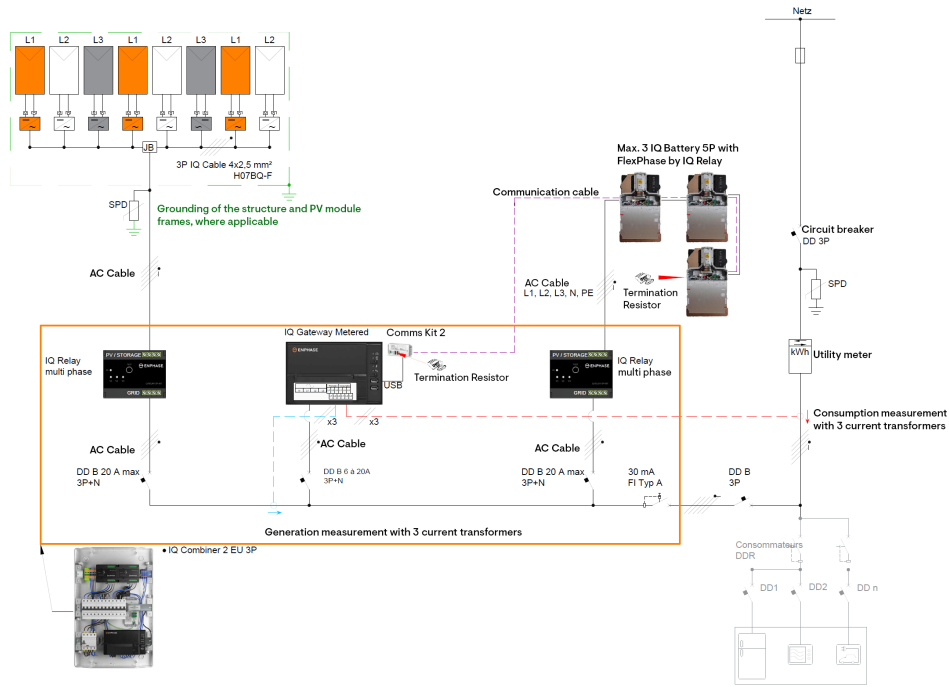

Figure 3: Three-phase IQ7/IQ8 Series Microinverters and IQ Battery 5P with FlexPhase configured in three-phase with IQ Combiner 2 EU 3P diagram

5.2.3 Solar PV and battery: Three-phase IQ7/IQ8 Series Microinverters and IQ Battery 5P with FlexPhase configured in three-phase with standalone IQ Gateway and Communications Kit 2

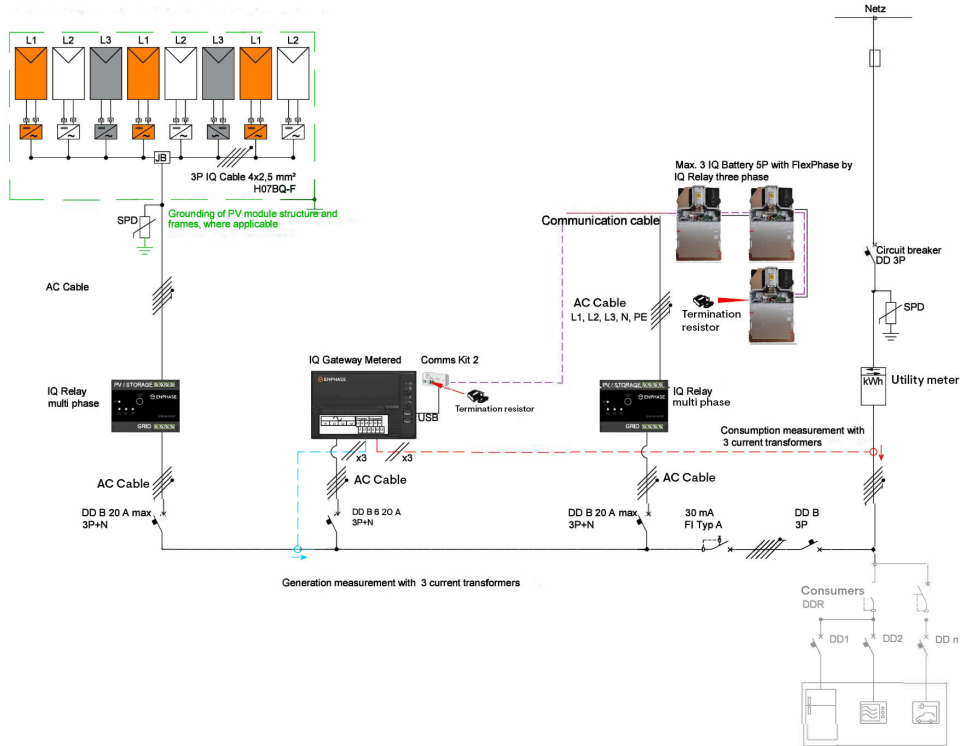

Figure 4: Three-phase IQ7/IQ8 Series Microinverters and IQ Battery 5P with FlexPhase configured in three-phase with standalone IQ Gateway and Communications Kit 2 diagram

5.2.4 Solar PV and battery: Three-phase string inverter and IQ Battery 5P with FlexPhase configured in three-phase with standalone IQ Gateway and Communications Kit 2

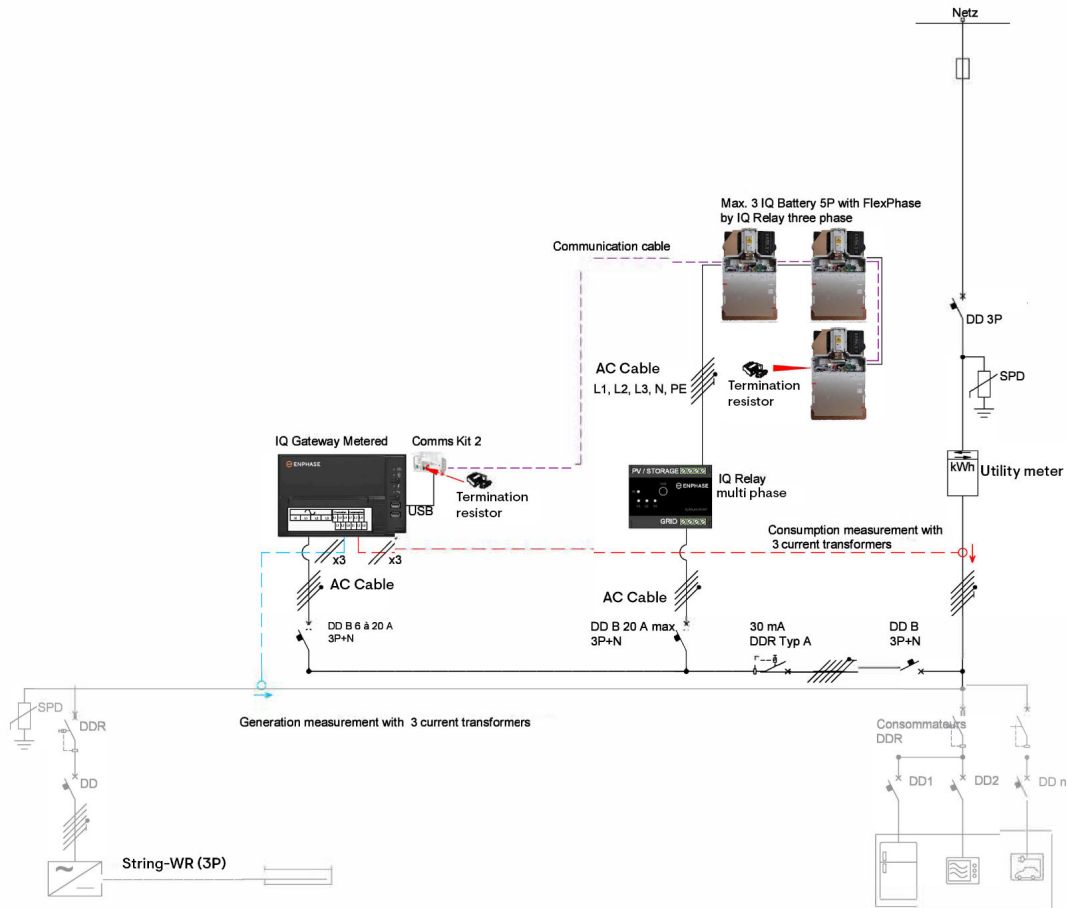

Figure 5: Three-phase string inverter and IQ Battery 5P with FlexPhase configured in three-phase with standalone IQ Gateway and Communications Kit 2 diagram

5.2.5 Solar PV and battery: Three-phase IQ7/IQ8 Series Microinverters and string inverter and IQ Battery 5P with FlexPhase configured in three-phase with standalone IQ Gateway and Communications Kit 2

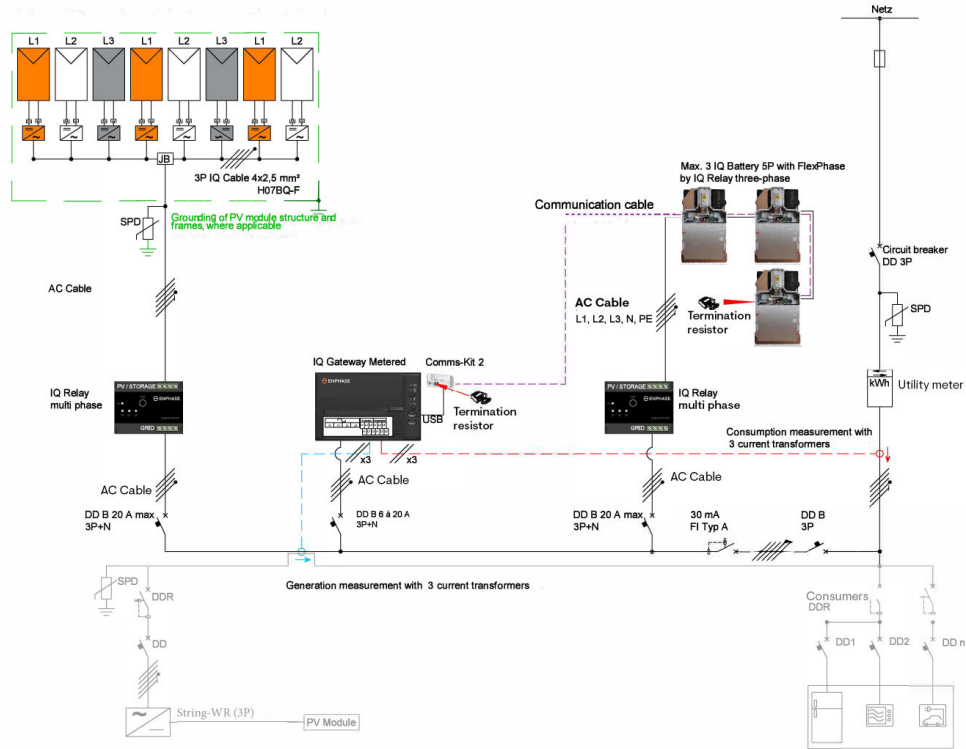

Figure 6: Three-phase IQ7/IQ8 Series Microinverters and string inverter and IQ Battery 5P with FlexPhase configured in three-phase with standalone IQ Gateway and Communications Kit 2 diagram

5.2.6 Solar PV and battery and HEMS: Three-phase IQ7/IQ8 Series Microinverters and IQ Battery 5P with FlexPhase configured in three-phase with IQ Combiner 2 EU 3P with HEMS

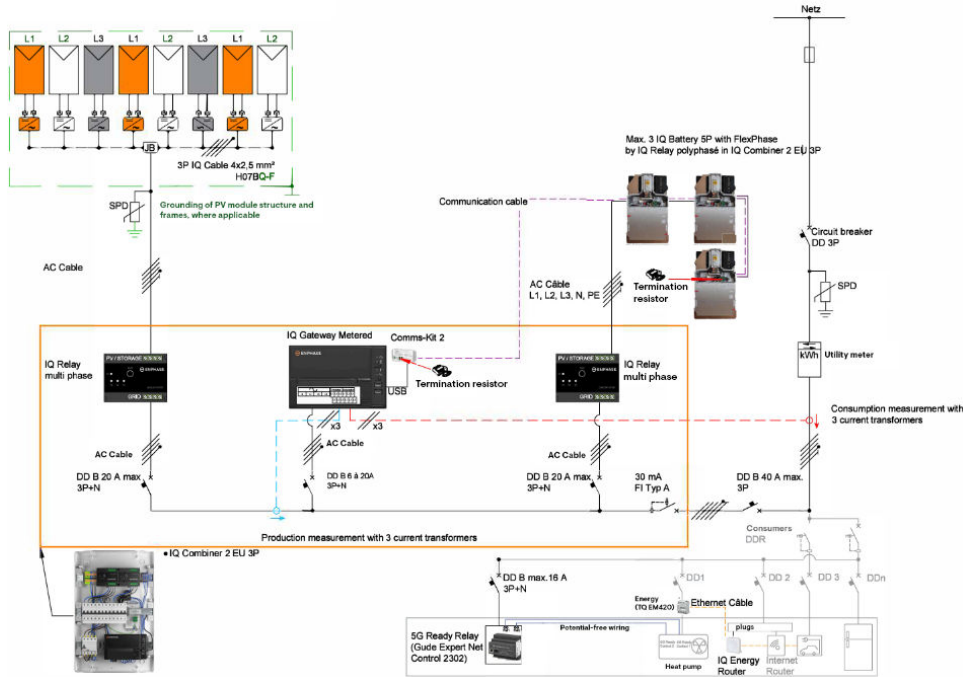

Figure 7: Three-phase IQ7/IQ8 Series Microinverters and IQ Battery 5P with FlexPhase configured in three-phase with IQ Combiner 2 EU 3P with HEMS diagram

6. Control wiring

An Enphase Energy System communicates over a wired communications interface between the IQ Gateway and IQ Battery 5P via the Communications Kit 2.

Use Enphase tested and qualified control cable (order code: CTRL-BL-EU-01) for optimal system performance. Use of non-approved cables can result in system performance issues and loss of warranties.

The following figure shows the guidance for correctly preparing the control (CTRL) cable.

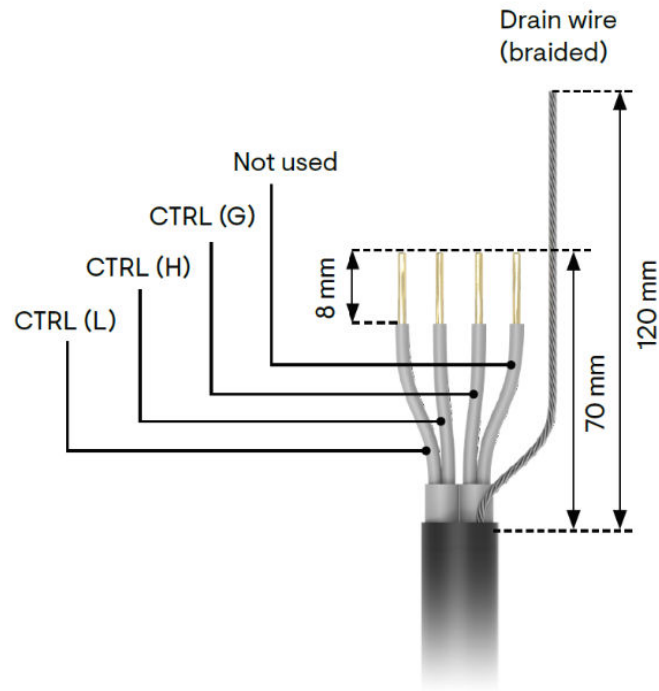

Figure 8: CTRL cable conductors stripping guidance

Table 4 lists the guidance for terminating the conductors of the CTRL cable into the CTRL header for the IQ Battery 5P with FlexPhase and the Communications Kit 2.

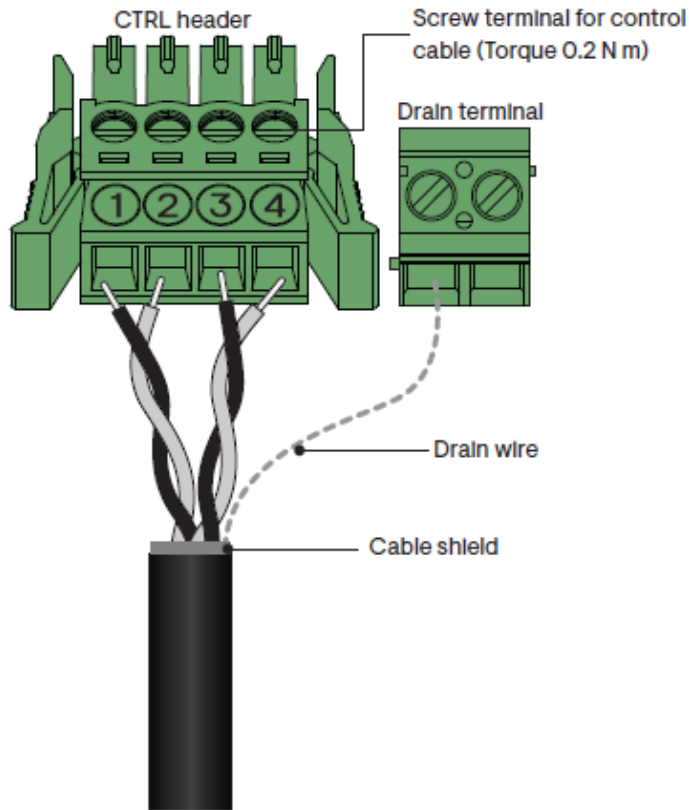

Figure 9: CTRL cable wire landing guidance

Table 4: Control cable connection guidelines

CTRL header numbers	CTRL signals	Conductor designation
Screw terminal 1	CTRL L	White with blue stripe
Screw terminal 2	CTRL H	Blue with white stripe
Screw terminal 3	CTRL G	White with orange stripe
Screw terminal 4	Not used	Orange with white stripe



NOTE: The total length of CTRL wiring across the system must not exceed 100 m to ensure optimal system performance.



NOTE: Follow the guidelines to avoid failures during system commissioning:

- One header with a termination resistor should be installed on each component that is at the extreme end of the control network.
- The drain wire should be terminated only at one end of each control wiring section or length.
- Terminating the drain wire at the component from which the control wiring for the section is initiated is recommended.

6.1 Control wiring guidance for installing IQ Battery 5P with IQ System Controller 3 INT

The following indicative wiring sequences are provided only for guidance and understanding to wire the control network:

6.1.1 Sequence 1: IQ Battery 5Ps – Communications Kit 2 INT

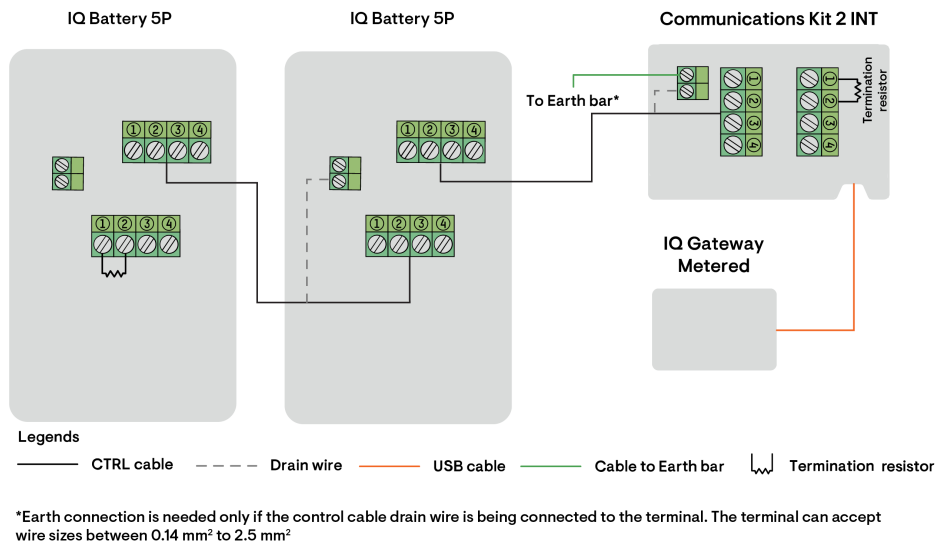

Figure 10: CTRL cable wire sequence 1

6.1.2 Sequence 2: IQ Battery 5P – Communications Kit 2 INT – IQ Battery 5P

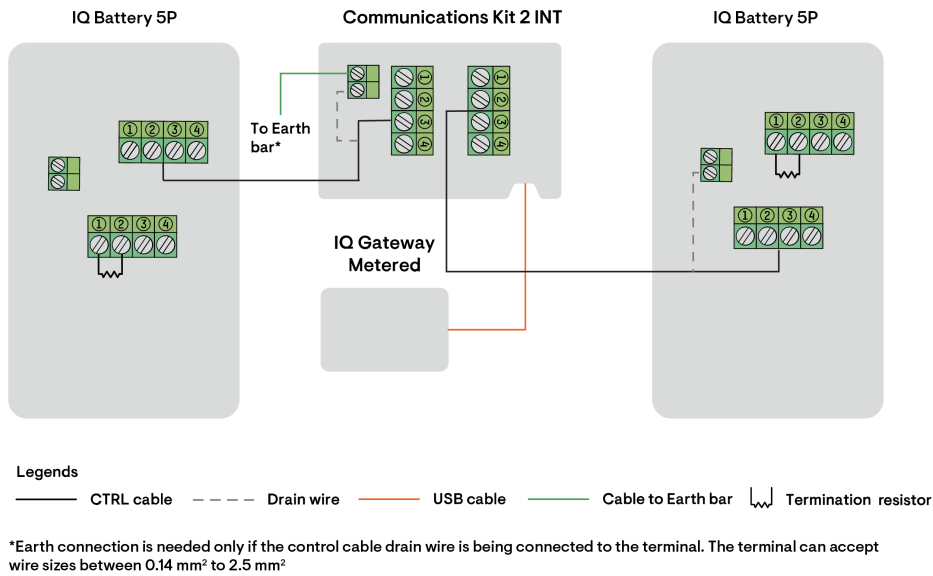

Figure 11: CTRL cable wire sequence 2

The following table lists the termination resistor locations for the preceding sequences.

Table 5: Termination resistor position guidance

Control wiring sequence	Termination resistor location
Sequence 1: IQ Battery 5P with FlexPhase-Communications Kit 2 INT	Resistor 1: First IQ Battery 5P with FlexPhase in the control bus Resistor 2: Communications Kit 2
Sequence 2: IQ Battery 5P with FlexPhase - Communications Kit 2 INT - IQ Battery 5P with FlexPhase	Resistors 1 and 2: The two IQ Battery 5P with FlexPhase units at each end of the control bus

Appendix A

Enphase components

The following table lists the order code for the Enphase components needed to complete a PV and battery installation. Refer to the IQ7/IQ8 PV and IQ Battery 5P with FlexPhase QIG and data sheet at the Enphase Documentation center to ensure that you select the appropriate components for your installation.

Table 6: Enphase components

Product type	Product	SKU
Enphase microinverters	IQ7 Microinverter	IQ7-60-2-INT IQ7-60-M-INT IQ7A-72-2-INT IQ7A-72-M-INT IQ7PLUS-72-2-INT IQ7PLUS-72-M-INT IQ7X-96-2-INT
	IQ8 Microinverter	IQ8MC-72-M-INT IQ8AC-72-M-INT IQ8HC-72-M-INT
Microinverter accessories	IQ Cable	Three-phase: Q-25-17-3P-160 2.5 mm ² IQ Cable for 60/96-cell, 1.7 m landscape module pitch
		Three-phase: Q-25-17-3P-160 2.5 mm ² IQ Cable for 60/96-cell, 1.7 m landscape module pitch
		Three-phase: Q-25-10-3P-200 2.5 mm ² IQ Cable for 60/72/96-cell, 1.0 m portrait module pitch
	IQ Terminator	Three-phase: Q-TERM-3P-10
	IQ Sealing Cap	Q-SEAL-10
	IQ Field Wireable Connectors (Female)	Three-phase: Q-CONN-3P-10F
	IQ Field Wireable Connectors (Male)	Three-phase: Q-CONN-3P-10M

Product type	Product	SKU
	Raw IQ Cable (meters)	Three-phase: Q-25-RAW-3P-300
	IQ Cable Clips	ET-CLIP-100
	IQ Disconnect Tool	Three-phase: Q-DISC-3P-10
⁵ Enphase gateway	IQ Gateway Metered	ENV-S-EM-230
Enphase battery	IQ Battery 5P with FlexPhase	IQBATTERY-5P-3P-INT
Enphase combiner	IQ Combiner 2 EU 3P	X-IQ-EURO-230-3P-4-2
⁵ Enphase communications kit	Communications Kit 2	COMMS-KIT-INT-02
Enphase-Belcom control cable	Control cable	CTRL-BL-EU-01

⁵ For sites being installed without the IQ Combiner 2 EU 3P, installers must procure the IQ Gateway Metered installers with additional Production and Consumption CTs along with a standalone Communications Kit 2 (COMMS-KIT-INT-02) to enable wired control communications.

8. Revision history

Revision	Date	Description
TEB-00226-2.0	July 2025	Added the English SLDs.
TEB-00226-1.0	December 2024	Initial release.